

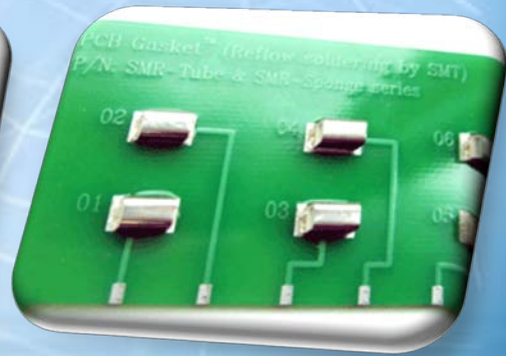

PCB Gasket & LopiVa



SENTRION
Corporation

www.sentrion.co.kr

www.sentrion.co.kr



PCB Gasket

[Conductive PCB gasket by SMT]

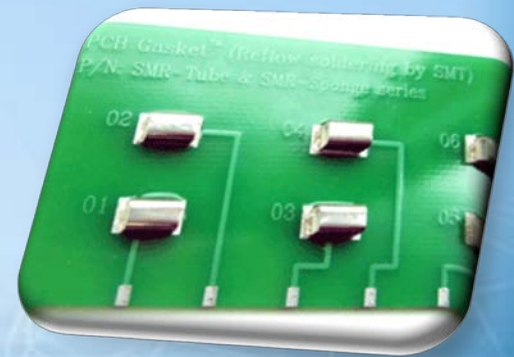



SENTRION - What is PCB Gasket

* What is PCB Gasket?

PCB Gasket is a soft electrical contact terminal which is useful for EMI solution, grounding and electrical terminal. Moreover SMT and reflow soldering are available.

Especially SMR series (one of PCB Gasket) has superior properties such as a good softness, an excellent recovery strength. That is composed of a very soft Silicon sponge as core and a PI film coated with copper & Sn as outer layer. Silicone gives excellent flexibility and recovery strength, and Sn offers excellent conductivity and anti-oxidation property. Also due to Sn, reasonable reflow soldering is possible and soldering strength is robust as well.

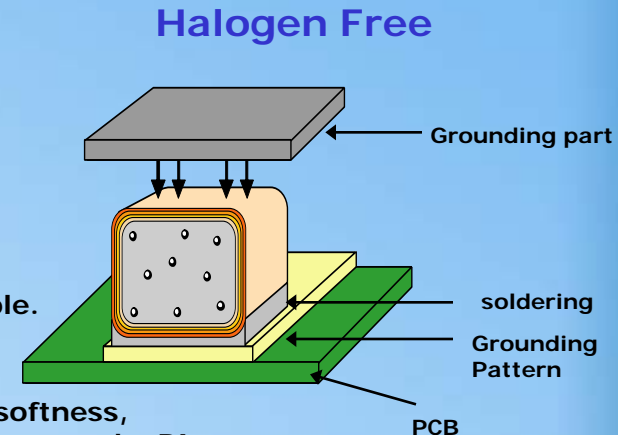

* Advantage

PCB Gasket
Advantage



- ▶ Improvement in productivity by SMT (cost-cutting)
- ▶ Soldering by reflow (keeping low contract resistance)
- ▶ Reliable adhesive strength with PCB by soldering (anti-aging)
- ▶ Rework is available after reflow
- ▶ Good conductivity at low compression rate (10~20%)
- ▶ Good fire retardant (UL 94 V-1)
- ▶ Pro-environment product (EU-RoHS satisfaction & Halogen free)
- ▶ Prevent oxidation by Sn plating layer of outline
- ▶ Patent against overseas

SENTRION - Constructions and features

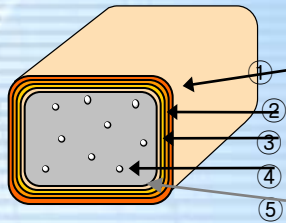

P/N : SMR-S

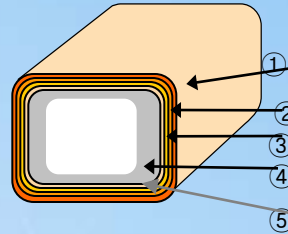

P/N : SMR-T

Item	Materials
①	Sn
②	Cu
③	PI Film
④	Silicon core (silicon tube or silicon sponge)
⑤	Adhesive

Features

- ▶ Good fire retardant (over UL 94 V-1)
- ▶ Good conductivity at low compression
- ▶ Good cushion & recovery strength

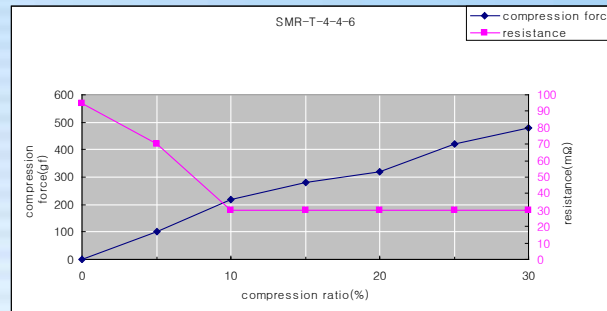

Compressive Force & Resistance with compression ratio

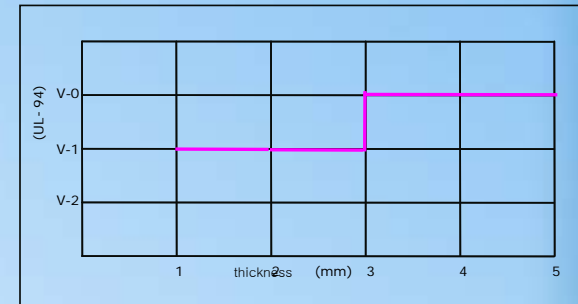

Fire retardant (UL 94)

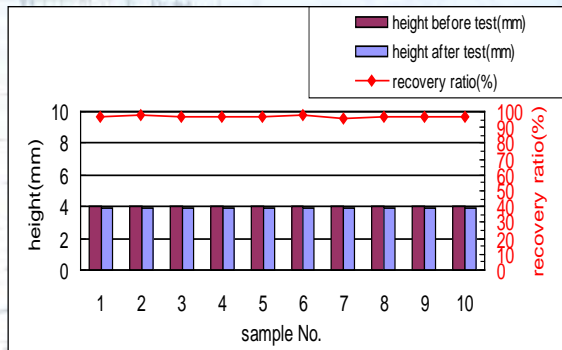

Recovery ratio after compression(20%) at 150°Cx100hr

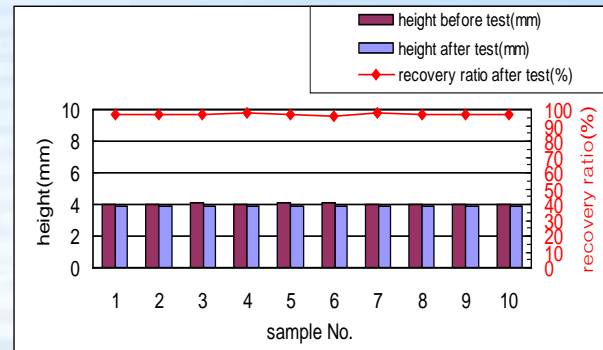

Recovery ratio after compression(20%) at -40°Cx100hr

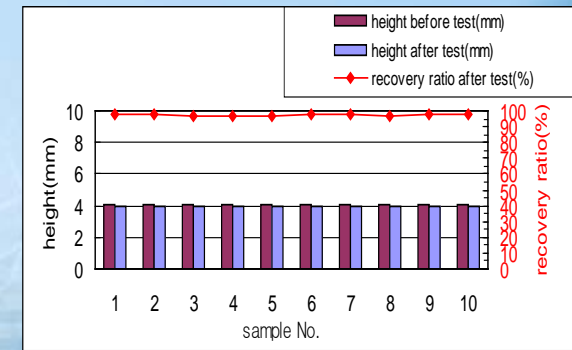

Recovery ratio after compression(20%) at 85%RHx100hr



SENTRION - Ordering

Part No.	Spec. [mm] - tolerance	
<u>SMR - T or S - W - H - L</u> Part No. Series No.	W	Order spec. ± 0.2
	H	Order spec. ± 0.2
	L	Order spec. ± 0.2

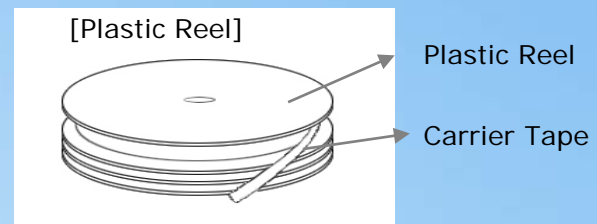

Reel packing

〈PCB Gasket Standard Packing Quantity〉

Part No.	PCB Gasket dimension [mm]			Carrier tape		Packing Quantity
	W	H	L	W	Pitch	EA/Reel
SMR-T or S-2-2-3	2	2	3	12	4	10,000
SMR-T or S-3-2-5	3	2	5	12	8	5,000
SMR-T or S-3-2.5-5	3	2.5	5	12	8	4,000
SMR-T or S-4-3-6	4	3	6	12	8	3,500
SMR-T or S-4-3.5-6	4	3.5	6	12	8	3,500
SMR-T or S-5-4-8	5	4	8	16	8	2,500
SMR-T or S-5-4.5-8	5	4.5	8	16	8	2,000
SMR-T or S-6-5-8	6	5	8	16	12	1,000

※ Packing could be changed.



SENTRION - Application



Mobile Phone



Touch pad

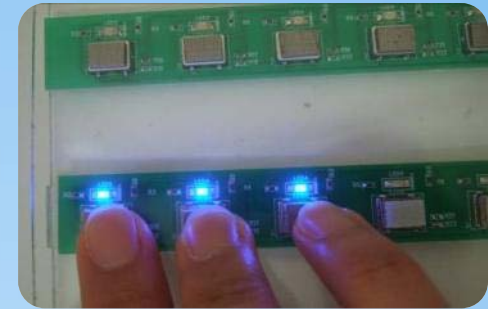

Touch sensor

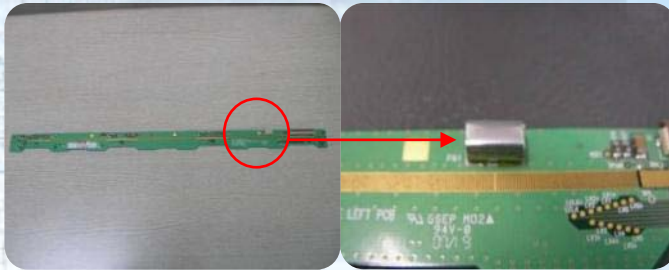

LCD Panel



Camcorder

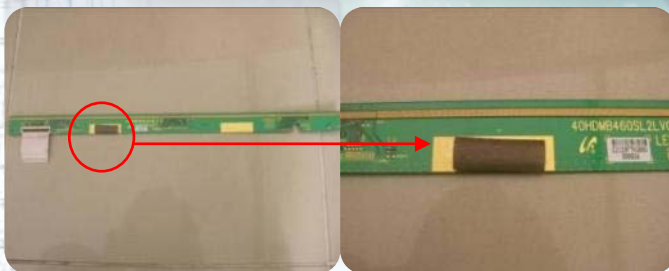

PCB Gasket Application

- 1) Electric contact & grounding
- 2) EMI/EMC solution
- 3) Cushion (absorb shock/protect other parts)
- 4) Application example
 - LCD/PDP display
 - Mobile device
 - Chip Antenna
 - Touch sensor / pad
 - Electric appliance
 - Automotive, etc

SENTRION - Characteristics

Item		Test Method	Spec.	Test result	
				SMR-S	SMR-T
Physical characteristics	Hardness	KSM 6519(Shore A)	25±5	Ave. 24	Ave. 26
	Recovery ratio (%)	75℃×48hr ,20%compression	Min. 80 %	Ave. 97%	Ave. 97%
Electrical characteristics (25℃)	Surface resistance (mΩ)	Agilent 4338B Miliohmmeter	Max. 100mΩ	Ave. 20mΩ	Ave. 20mΩ
	Vertical resistance (mΩ)	DS-1100 compression tester		Ave. 30mΩ	Ave. 30mΩ
Environmental Reliability characteristics	High T. /High H	Resistance	85℃, 85%RH, 100hr	Max. 100mΩ	Ave. 30mΩ
		appearance		No discoloration	No discoloration
	Salt water spraying	Resistance	12hours (KSD 9502)	Max. 100mΩ	Ave. 30mΩ
		appearance		No discoloration	No discoloration
	Thermal shock	Resistance	-40℃ → 85℃, 30 times	Max. 100mΩ	Ave. 30mΩ
		appearance		No discoloration	No discoloration
	Hazardous substance		EU-RoHS	compliant	compliant
			Halogen Free	compliant	compliant
			Sulfur	None	None
			Out-gas	None	None
Fire retardant		UL 94 [File No.:E250169]	V-2	V-1	Over V-1
Characteristics after SMT *Reflow condition refer to page.9	Vertical resistance (mΩ) after SMT	DS-1100, compression tester	Max. 100mΩ	Max. 50mΩ	Max. 50mΩ
	Adhesive strength (Kgf) with PCB After SMT	DPS-5R [IMADA]	Min. 0.8Kgf	Min. 1.2 kgf	Min. 1.2 kgf



SENTRION - Test Method

1. Appearance

: check foreign substance and discoloration with naked eye

2. Dimension

: Measure with Digital Caliper

3. Hardness

: Measure with Shore-A[Model : GS-701G] in accordance with KS M 6519

4. Measure surface resistance

: Measure with 4338B Milliohmmeter, under 10% compressed condition as below picture.



5. Vertical resistance

: Measure under 10% compressed condition.

6. Soldering strength

Measure the surface resistance after surface mounting on PCB substrate.

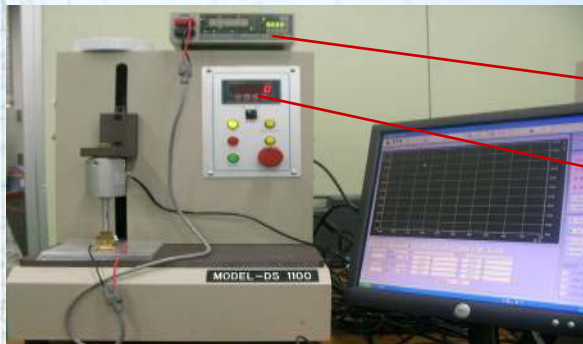

Measure resistance

Measure compression

DS-1100



DPS-5R[IMADA] Push-Pull Tester



SENTRION - Reliability test method

Item	Test method
High Temp.& Humidity test	Measure the resistance after keeping the sample 100 hours in condition of 85°C,85%RH
Thermal shock test	Keep the sample in -40°C for 30 minutes right after keeping in 85°C for 30 minutes. Measure the resistance after 100 times with this method.
Salt water spraying test	Test the salt water spraying in condition of the concentration of salt water 5%, test temperature 35°C, and test time 12hours in accordance with MIL-STD-202/KS D 9502

8. Reflow Condition

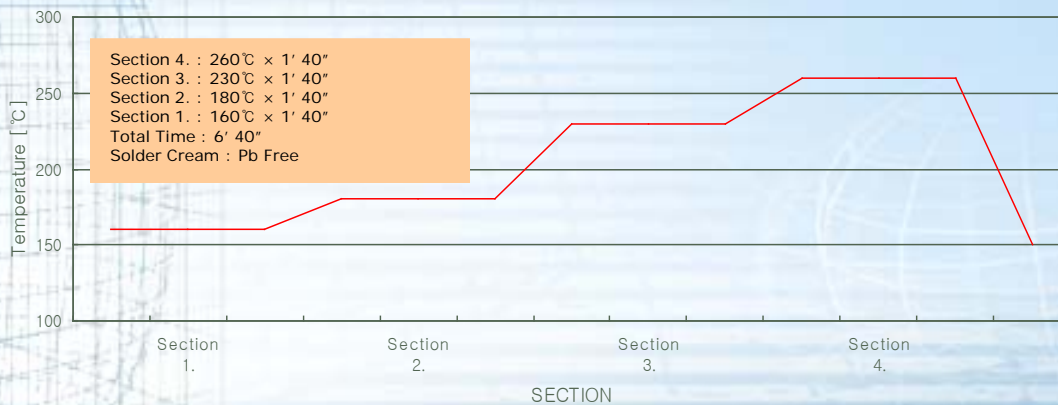



SENTRION - Check points on SMT

SMT (Surface Mounting Technology) means a technology that connect to the connecting pattern on PCB surface by soldering when connecting electronic parts to PCB. High-density mounting is realized by this technology.

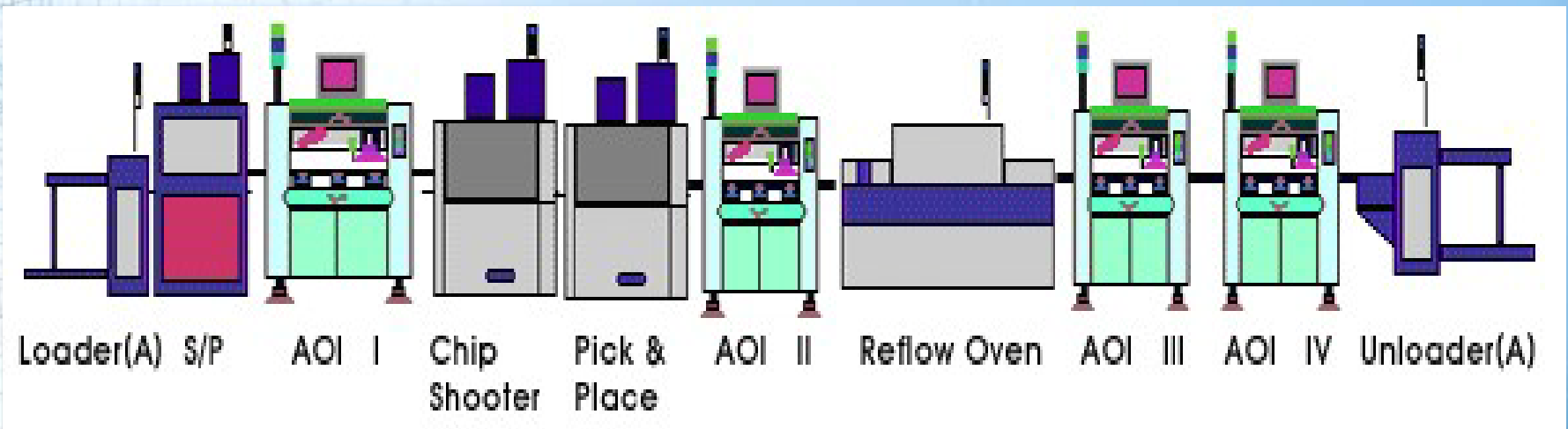



SENTRION - Check points on SMT

* Solder Land design

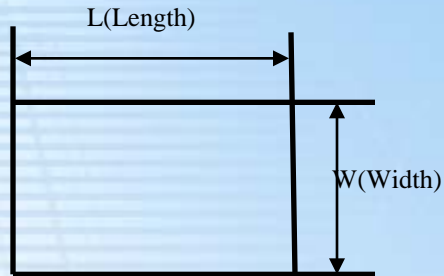

< PCB Gasket size >

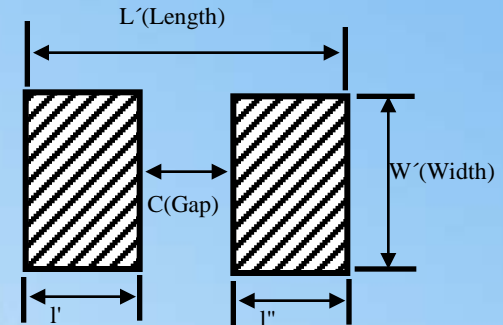

< Solder land size >

< Example of PCB Gasket VS Solder land >

P/N	PCB Gasket size (mm)			Solder Land size (mm)		
	W[width]	H[height]	L[length]	W'	L'	C[Gap]
SMR-2-2-3	2.0	2.0	3.0	2.4	4.0	0.5
SMR-3-2.5-5	3.0	2.5	5.0	3.6	6.0	1.0
SMR-4-3-6	4.0	3.0	6.0	4.8	7.0	1.5
SMR-4-4-6	4.0	4.0	6.0	4.8	7.0	1.5
SMR-5-4-8	5.0	4.0	8.0	5.8	9.0	2.5
SMR-6-5-8	6.0	5.0	8.0	6.8	9.0	2.5

Metal mask thickness : 0.08 ~ 0.15mm



SENTRION - SMT state by Solder Land

* SMT state by Solder Land

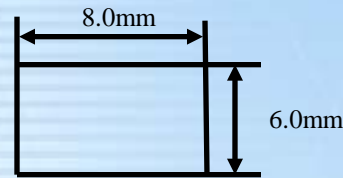
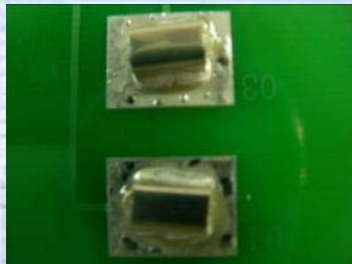

Before solder land design

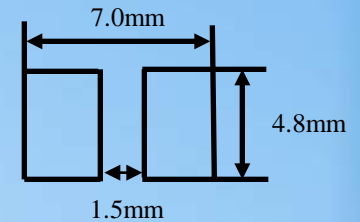
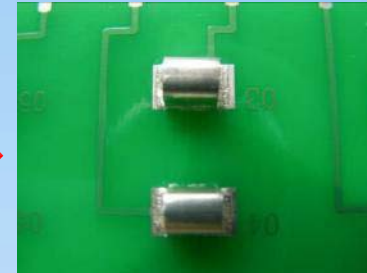

After solder land design

► Solder Land size is designed wrongly for PCB Gasket, So it moves by cohesive power of solder cream after reflow.

► Solder Land size was designed rightly for PCB Gasket, it doesn't move after reflow.

* SMT state by pick up position when mounting

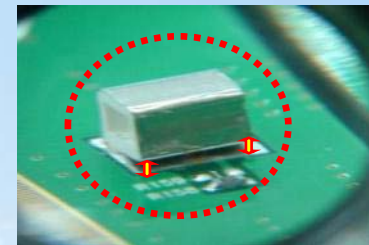
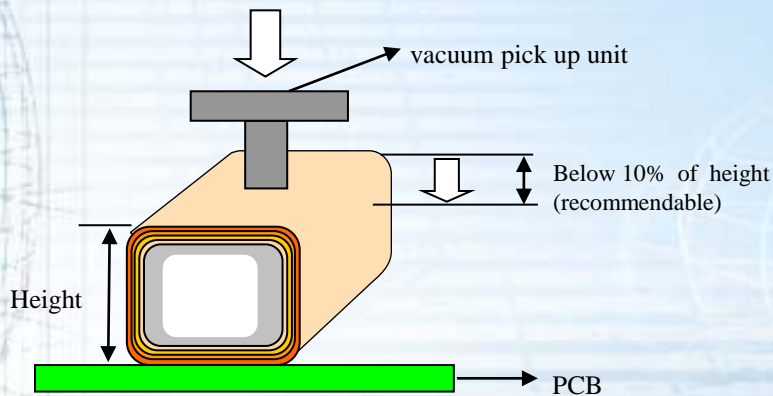

Getting loose problem
(P/N: SMR-T-4.5-4.5-6)

When mounting the product on PCB, mounting at over 10% of height, as printed solder cream leans to the right/left, product gets loose when reflow.



SENTRION - Test Report / Certificate

E250169, 08CA16316
 2008-05-27
 Page 2 of 2

TABLE I
 MATERIAL PROPERTIES

Material Designation	Color	Min. thk mm	UL94 Flame Class	H W I	H A I	H V T R	D 4 5	C T I	H V A R	Diel Str+ Kv/mm	Vol Res ohm-cm	Dim Stab %	H ₂ O Abs. %	H D T °C	Ten Imp kJ/m ²	Ten Str mPa	Izod Imp J/M	Flex Str mPa	G W I °C	G W F °C	Ball Pres °C
SMR-S-(a)-(d)	Silver	1.0 - 7.0	V-1	-	-	-	-	-	-	-	-	-	-	-	-	-	-	-	-	-	-
SMR-T-(e)-(f)	Silver	1.3	V-1	-	-	-	-	-	-	-	-	-	-	-	-	-	-	-	-	-	-
	Silver	3.0 - 10.0	V-0	-	-	-	-	-	-	-	-	-	-	-	-	-	-	-	-	-	-

TABLE II
 CNR MATERIAL PROPERTIES

Material Designation	Color	Minimum Thickness(mm)	Flame Class	HWI (s)	HAI (arc)	CTI (V)	HVA R (s)
SMR-T-(e)-(f)	Silver	1.3	V-1	-	-	-	-
	Silver	3.0 - 10.0	V-0	-	-	-	-

(e) - Denotes width size from 1.5mm to 10mm
 (f) - Denotes thickness from 1.2mm to 10mm



LopiVa





SENTRION - LopiVa

LopiVa E series

zero signal distortion : <8GHz

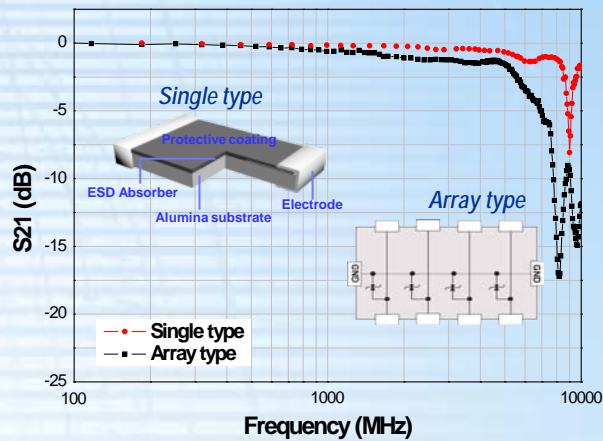

Features

- EU-RoHS Compliance
- Protection against ESD
- Ultra-low capacitance : 0.1pF
- Ultra-low leakage current : 1nA
- Zero signal distortion : < 8GHz
- Bi-directional

Description

As data transmission speed through interface of HDMI, USB2.0 etc. is moved to high frequency region(<8GHz), needs of ESD protection device of ultra-low capacitance below 0.8pF not to be distorted original signal are increased.

LopiVa E series have ultra-low capacitance of 0.1pF as ESD protection device, and could maintain for insertion loss to zero dB until 8GHz. Also, This product is effective in reducing an energy loss in circuit due to very low leakage current below 1nA.

LopiVa 4ch array is designed to protect four signal line from ESD. This device is effective in saving space of circuit and reducing SMT process cost.

LopiVa E series and LopiVa 4ch array are a product family based on the patents technique that is registered by Joinset Co.,Ltd.

Main function

This product family is a passive device to perform the role of circuit protection against transient voltage such as ESD, which is suitable to high speed data line up to 8GHz.



SENTRION - LopiVa

Application

- a. HDMI Digital Interface / Terminals ; LCD & PDP TV, Set-top Box, DVD player etc.
- b. Satellite Radio system, Navigation, Cellular phone
- c. Telecommunication transient protection
 - USB2.0 port, IEEE-1394, HDMI, RF module, Antenna circuit

* ESD suppressor effect

Items	OPEN waveform (Ref.)	LopiVa single/array
Wave form	<p>without ESD absorber</p> <p>Ch1 최대 2.88kV</p> <p>Ch1 500V</p> <p>M 40.0ns A Ch1 180V</p> <p>131.200ns</p>	<p>with LopiVa single/array</p> <p>Ch1 최대 940V</p> <p>Ch1 500V</p> <p>M 40.0ns A Ch1 250V</p> <p>120.000ns</p>
Test method	<p>Discharge gun</p> <p>Test sample</p> <p>ESD simulator</p> <p>60dB attenuator</p> <p>oscilloscope</p> <p>Measuring ESD waveform through resistor(200ohm), when ESD of 8kV is applying.</p>	



SENTRION - Single type (LopiVa E series)

Shape & Dimensions

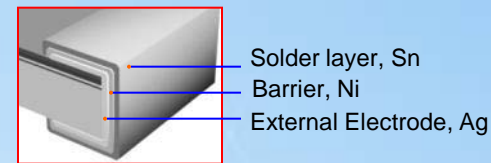
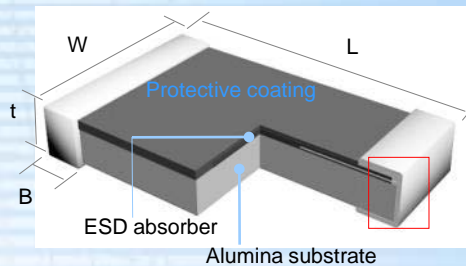

Series	Length(L)	Width(W)	Thickness(t)	B
LopiVa 05G12E	1.6±0.2	0.8±0.2	0.55±0.1	0.4±0.2
LopiVa 16G12E	1.0±0.1	0.5±0.1	0.40±0.1	0.2±0.1

Electrical characteristics

Capacitance @1MHz,1Vrms	Max. Operating Voltage	Max. Leakage Current	ESD			
			Capability		Vp	Vc
0.1pF	24V	1nA	contact	8kV	350V	30V
			air	15kV		

* Frequency property : Capacitance , Insertion Loss(S21)



SENTRION - Single type (LopiVa E series)

* *Frequency property : Capacitance , Insertion Loss(S21)*

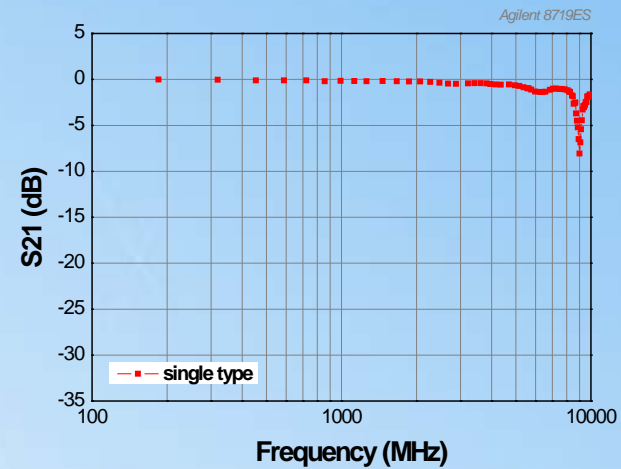
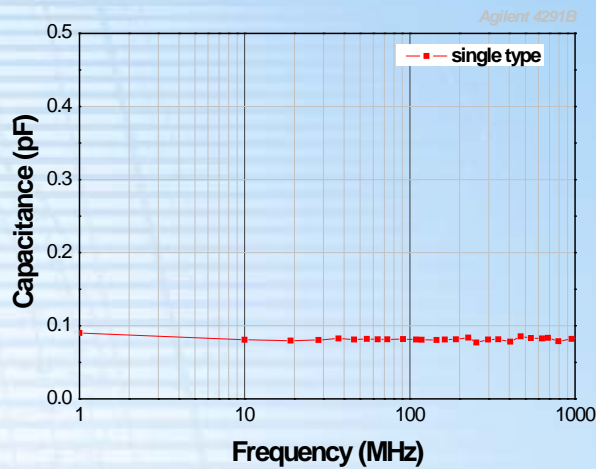

Application

(a) **HDMI**

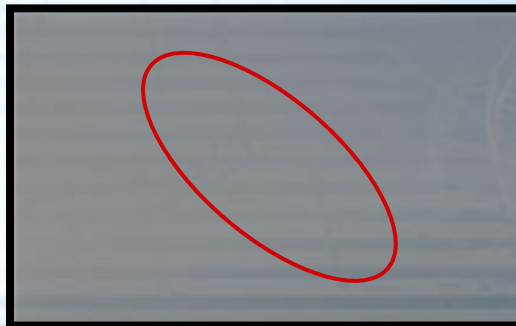

(b) **USB2.0**

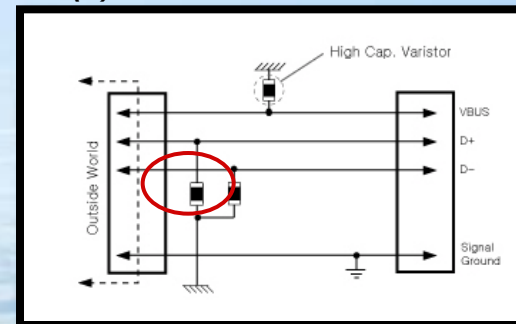



SENTRION - Array type (4channel)

Shape & Dimensions

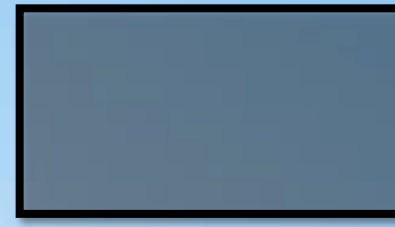
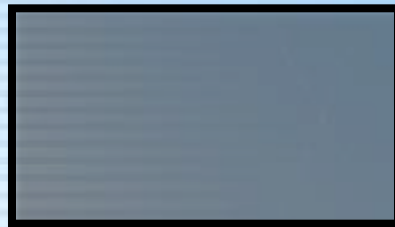

Series	Length(L)	Width(W)	Thickness(t)	a	b	c	d
LopIva16G12A4G	1.6±0.1	0.8±0.1	0.55±0.1	0.20±0.1	0.20±0.1	0.20±0.1	0.25±0.1
LopIva20G12A4G	2.0±0.1	1.25±0.1	0.60±0.1	0.20±0.1	0.25±0.1	0.25±0.1	0.30±0.1

Equivalent circuit diagram (port 1)

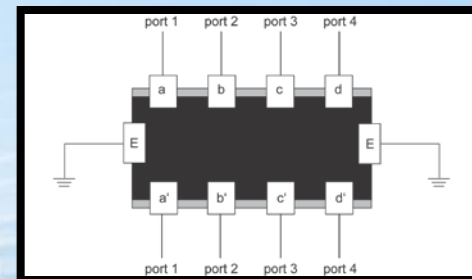
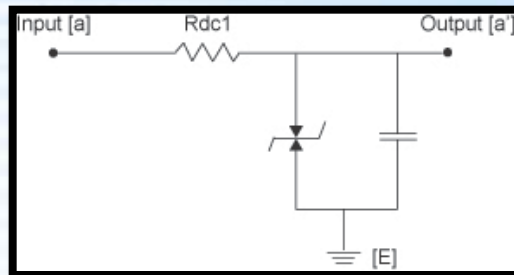

Rdc2: Resistance between E and E'



SENTRION - Array type (4channel)

Electrical characteristics

Capacitance @1MHz,1Vrms	Max. Operating Voltage	Max. Leakage Current	Rdc1/ Rdc2	ESD			
				Capability		Vp	Vc
0.3pF	24V	1nA	0.05ohm	contact	8kV	350V	30V
				air	15kV		

*** Frequency vs Insertion Loss(S21, Port 1)**

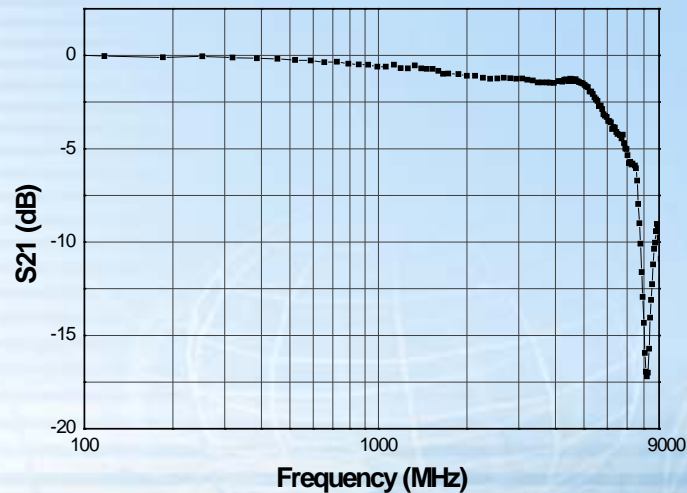



SENTRION - Application

(a) HDMI

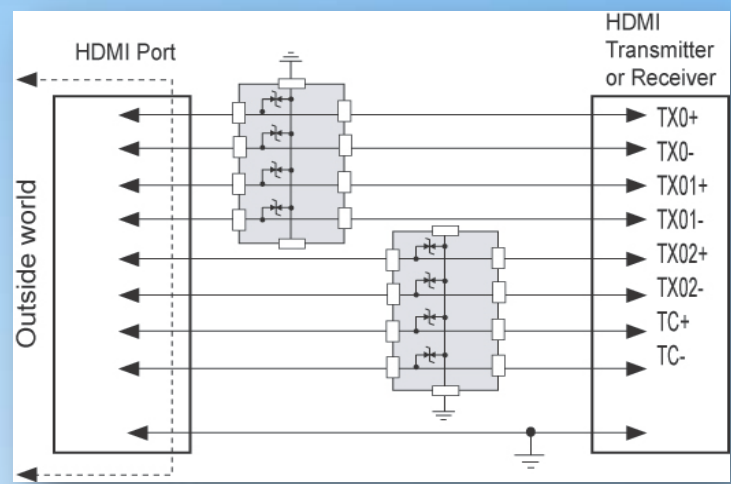

(b) 10/100 Ethernet differential Protection

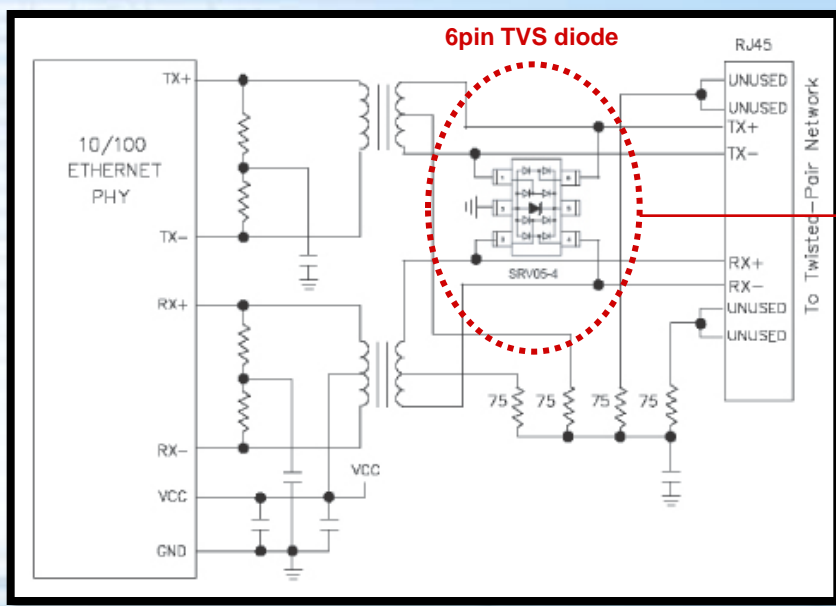

LopiVa 20G 12A 4G

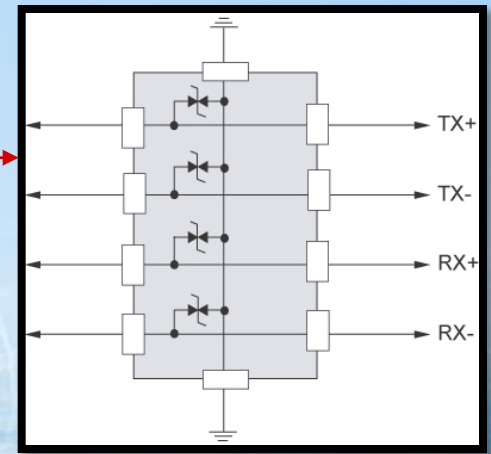



SENTRION - Global Office

KOREA HEAD OFFICE

Tel +82-2-858-0027 / Fax +82-2-858-0028

Marketing@sentrion.co.kr

HONGKONG OFFICE

Tel : +852-2433-3116 / Fax : +852-3007-6427

JoeyChu@sentrion.com.hk

CHINA (GuangZhou) OFFICE

Tel : +86-20-3478-4219 / Fax : +86-20-3479-4209

Tony@sentrion.cn

CHINA (ShenZhen) OFFICE

Tel : +86-755-8299-7481 / Fax : +86-755-8299-5386

DuKim@sentrion.co.kr